



FOAM, GLUE, TAPE AND A LITTLE IMAGINATION....



(RC Model Airplane Construction Plans)

rcFoamFighters

FF-15 (Foam Fighter 15)

(Original Design by Paul Petty - Jan-Sept. 2009)

(CAD Drawing by Paul Petty - Sept. 2009)

Basic Template Release Ver. 1.1

FREE PLAN - NOT TO BE SOLD

rcFoamFighters

FF-15 (Foam Fighter 15)

Basic Template

(Design by Paul Petty - Jan.-Sept. 2009 - Rev 1.1)

(CAD Drawing by Paul Petty - Sept. 2009)

(Basic Template Release 1.1 - Copyright rcFoamFighters)

(Contact rcFoamFighters at: admin@rcfoamfighters.com)

(Please Visit Our Blog at: <http://rcfoamfighters.com/blog/>)



Approximate CG is 14-3/8" back from the tip of the nose.

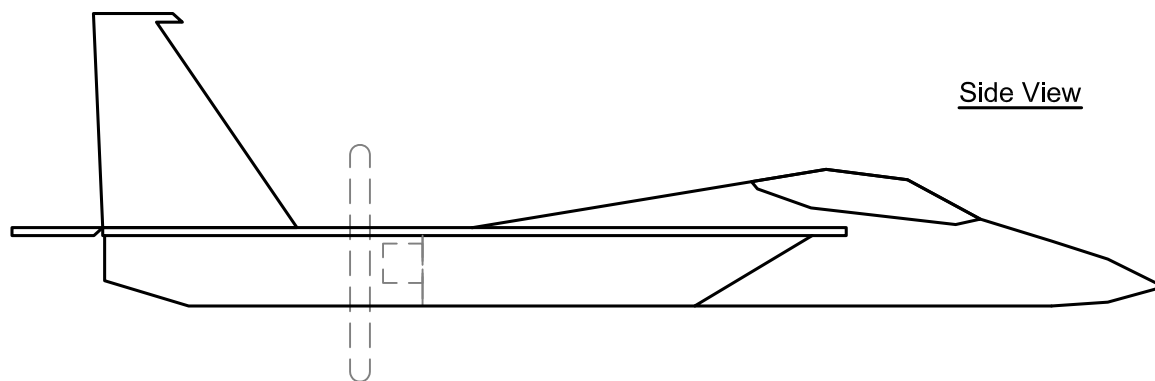
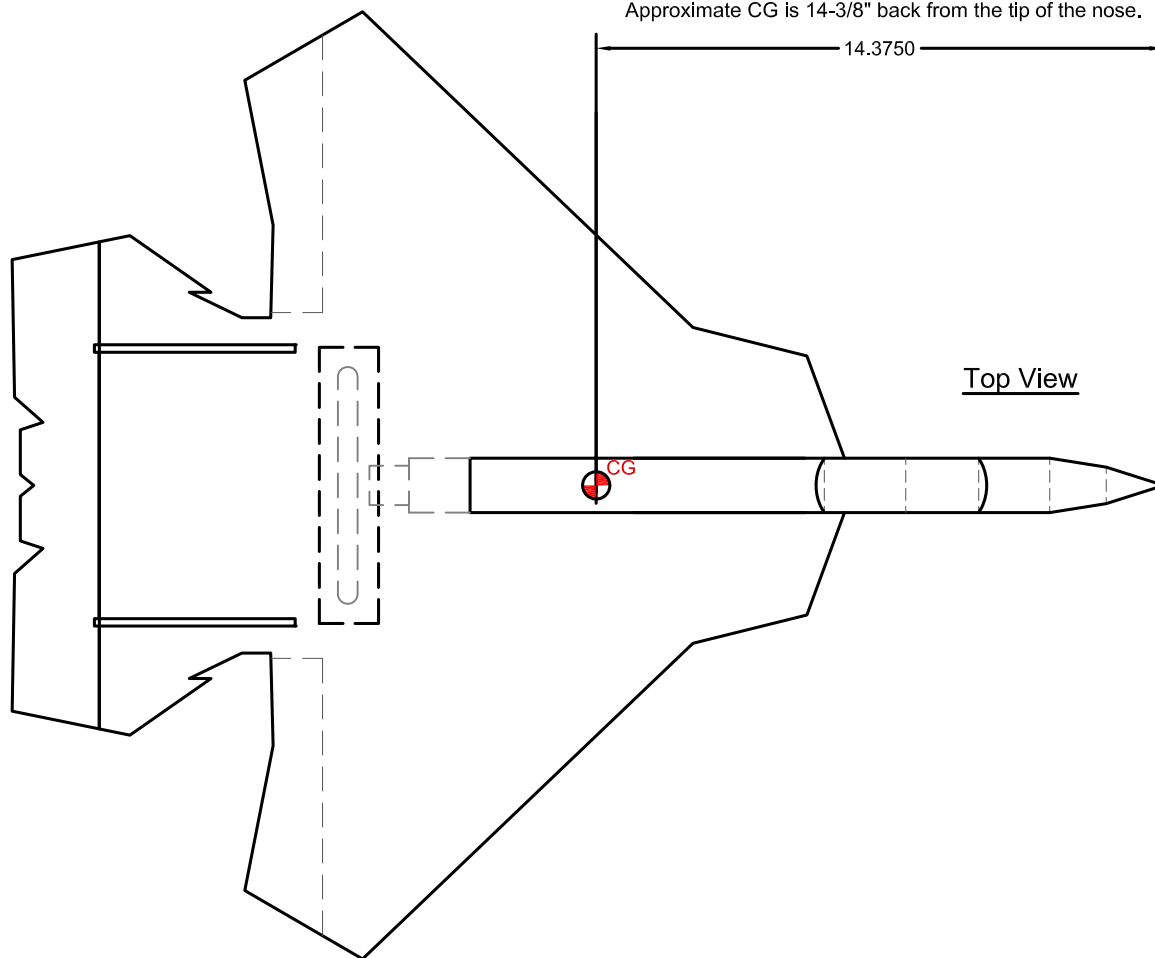

Recommend Parts:

BASIC SETUP (70+mph)

Motor: Suppo A2212/6 2200kV Brushless Motor
ESC: Suppo 30A Brushless ESC
Prop: APC 6x4
Battery: 1800mA (25C or better recommended)
Servos: 3 Each Micro Metal Gear
Radio & Receiver: Any 6-channel or better (2.4ghz preferred)

PERFORMANCE SETUP (85+mph)

Motor: Grayson Hobbies "Super Mega Jet" 2550kV Motor
ESC: 40A Brushless ESC
Prop: APC 6x5.5
Battery: 2200mA (30C recommended)
Servos: 3 Each Micro Metal Gear
Radio & Receiver: Any 6-channel or better (2.4ghz preferred)

Plane was originally designed to be made from 2 Sheets of 20x30 Foamboard.
Depron or FanFold Foam with Carbon Spars may be used .

Disclaimer (Please Read):

- This is a design template for a high performance, high speed RC aircraft. This plane should only be built and flown by experienced pilots with adequate skill to fly fast, maneuverable planes.
- DO NOT fly this plane where it can endanger people, livestock or property.
- This plane should only be launched via the side launch method. Do not attempt to launch from the top or bottom of the fuselage. Doing so can cause bodily harm if any hand or body part comes into contact with the fast spinning propeller.
- All minors should fly under the supervision of an adult or guardian.
- ANY PERSON DECIDING TO BUILD AND FLY THIS PLANE DOES SO AT HIS/HER OWN RISK.
RCFOAMFIGHTERS ASSUMES NO RESPONSIBILITY FOR THE PERFORMANCE OF THIS PLANE.

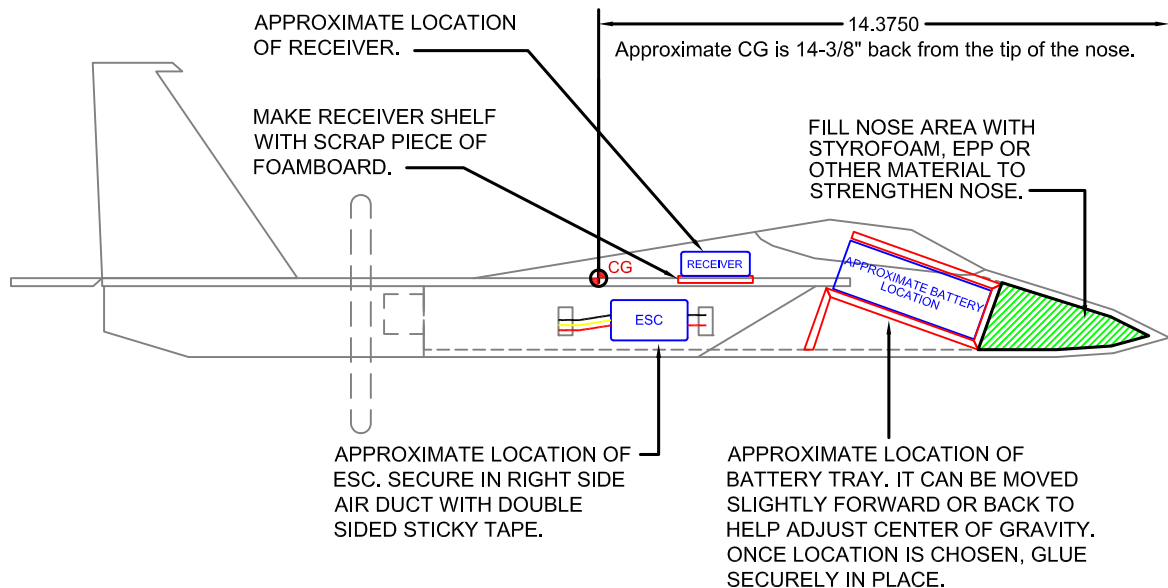

SCRATCH BUILT BASSWOOD MOTOR MOUNT (MADE FROM 3/32" BASSWOOD SHEETS)

ASSEMBLE

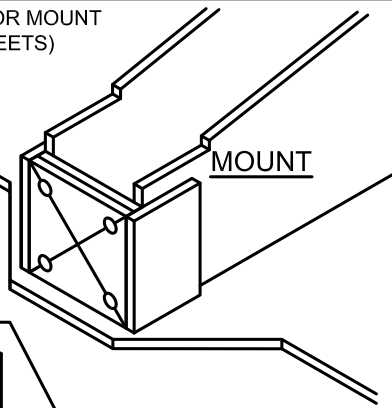
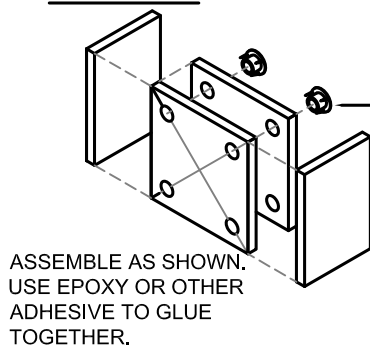

INSERT 4 EACH, 4-40 BLIND NUTS INTO BACK OF MOTOR MOUNT PLATE. INSURE HOLE PATTERN IS DRILLED TO MATCH MOTOR TO BE USED. (USE 4 EACH 4-40 HEX BOLTS TO SECURE MOTOR TO MOUNT.)

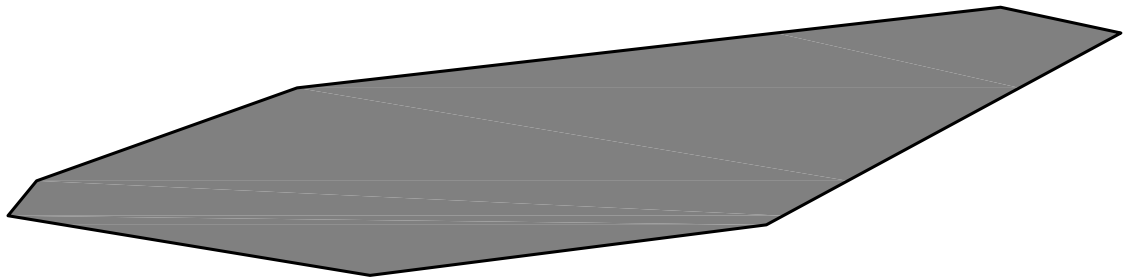

BACK

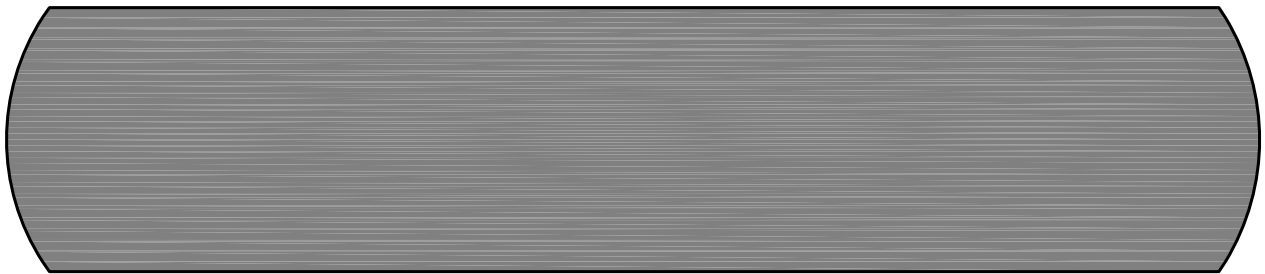

FRONT

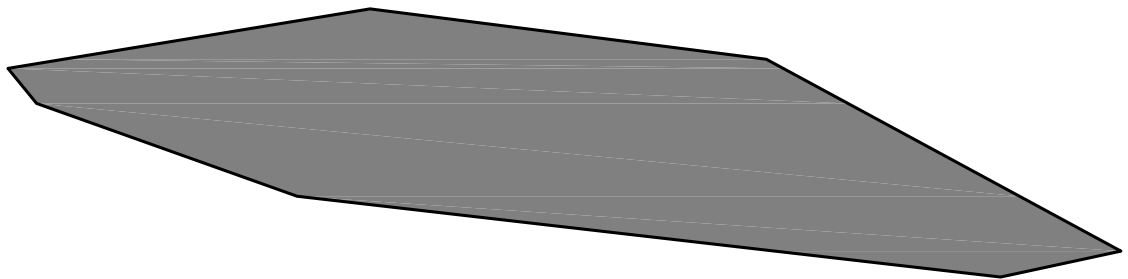

Cockpit Glass Templates

These can be used as patterns to cut the cockpit glass out of black tape or other material.

TEMPLATE ASSEMBLY KEY PLAN

rcFoamFighters

FF-15 (Foam Fighter 15)

(Design by Paul Petty - Sept. 2009 - Rev 1.1)

(CAD Drawing by Paul Petty - Sept. 2009)

INSTRUCTIONS:

PRINT ALL TEMPLATE SHEETS. CUT AND ASSEMBLE AS SHOWN BELOW. USE SCOTCH TAPE TO SECURE SHEETS TOGETHER.

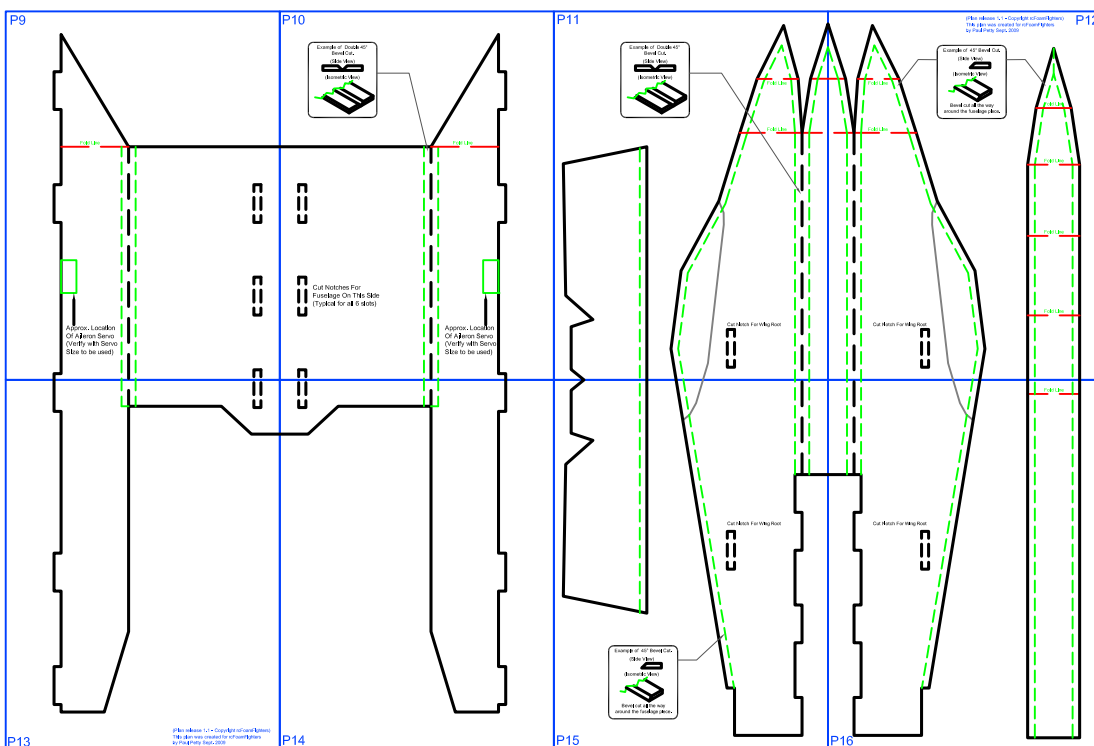
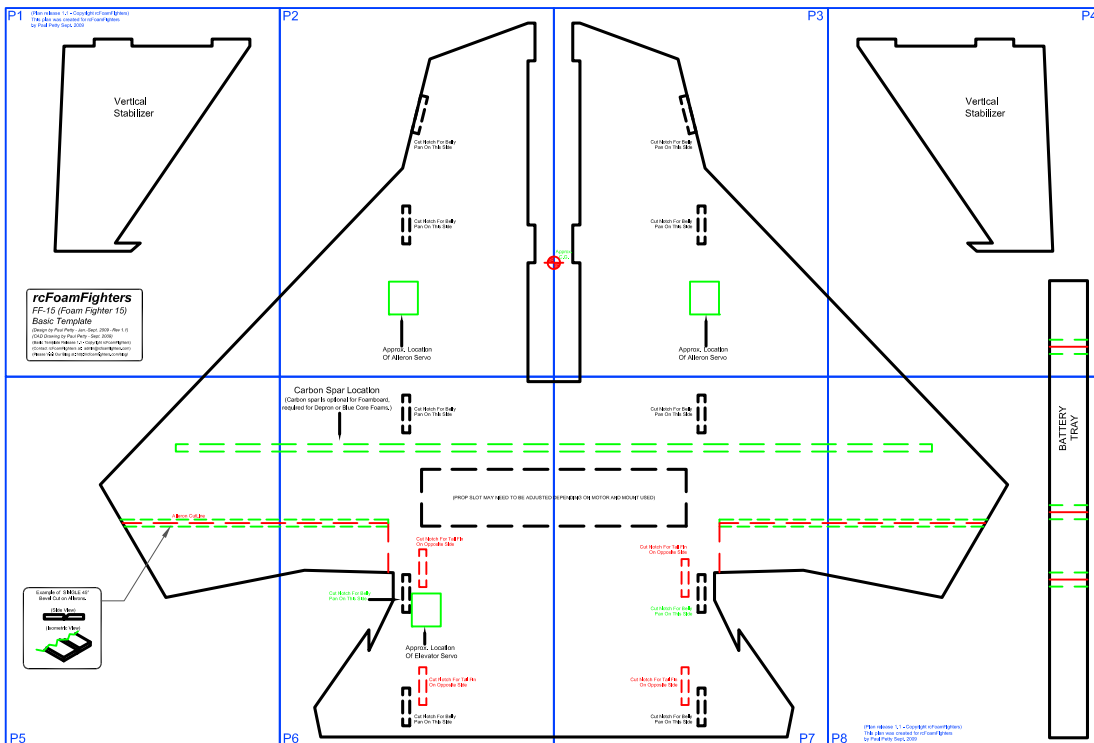

P1

(Plan release 1.1 - Copyright rcFoamFighters)
This plan was created for rcFoamFighters
by Paul Petty Sept. 2009

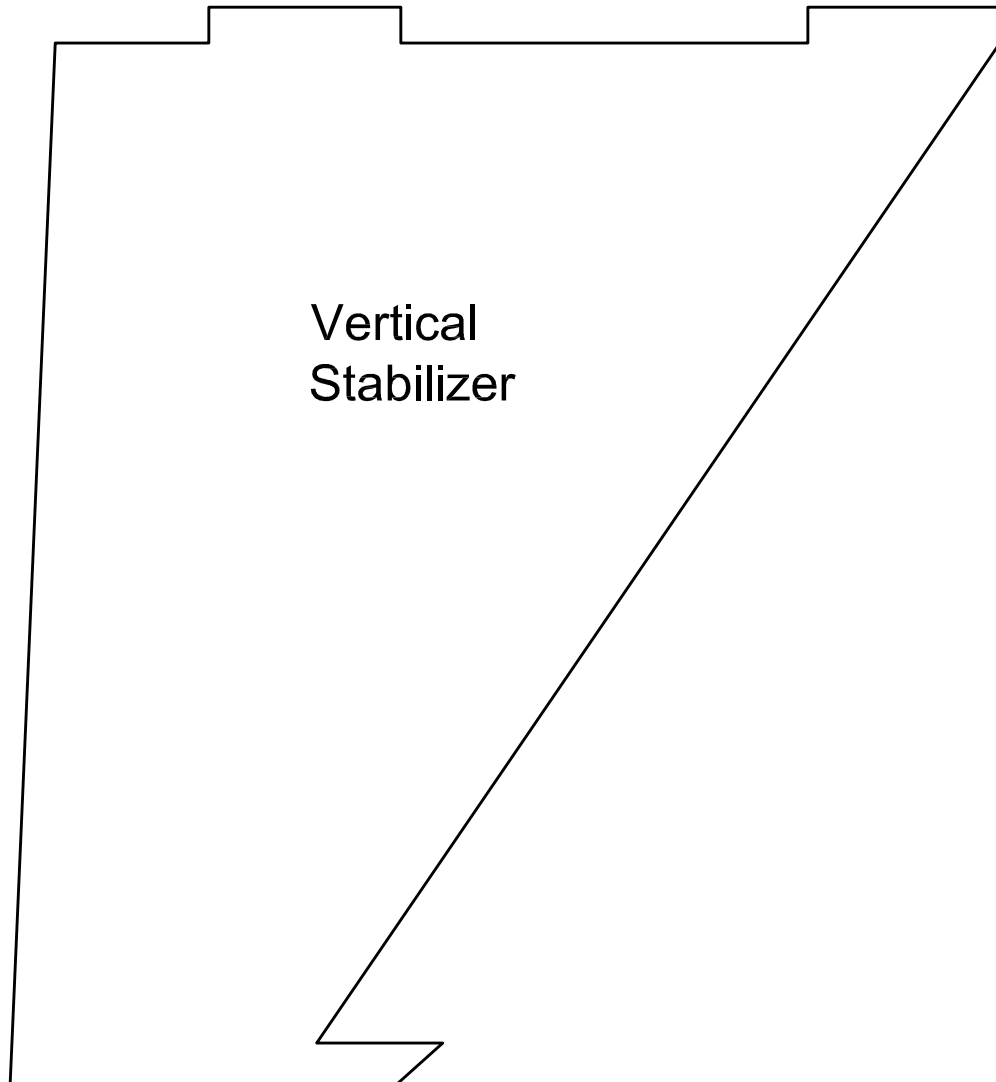

rcFoamFighters

FF-15 (Foam Fighter 15)

Basic Template

(Design by Paul Petty - Jan.-Sept. 2009 - Rev 1.1)

(CAD Drawing by Paul Petty - Sept. 2009)

(Basic Template Release 1.1 - Copyright rcFoamFighters)

(Contact rcFoamFighters at: admin@rcfoamfighters.com)

(Please Visit Our Blog at: <http://rcfoamfighters.com/blog/>)

P2

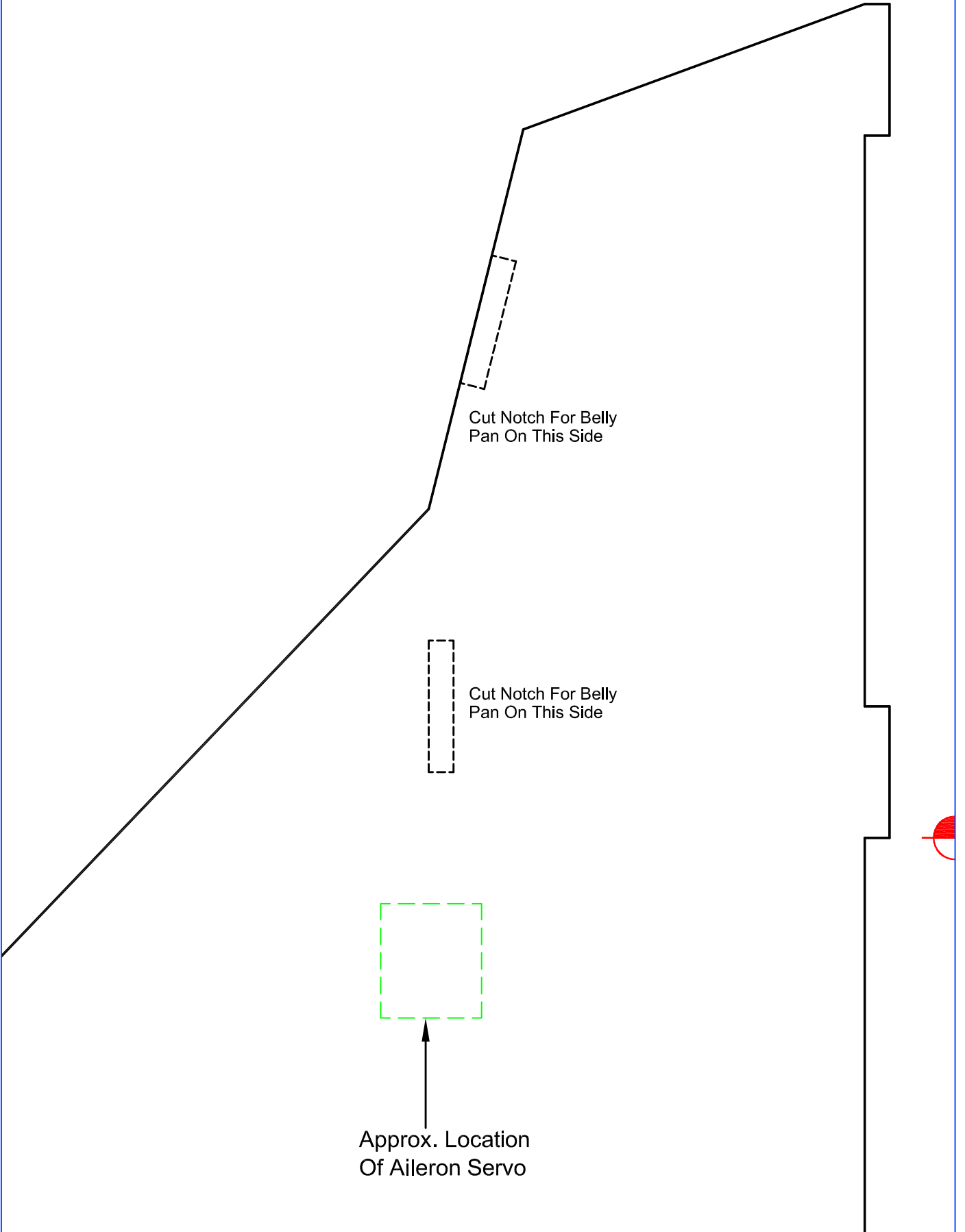

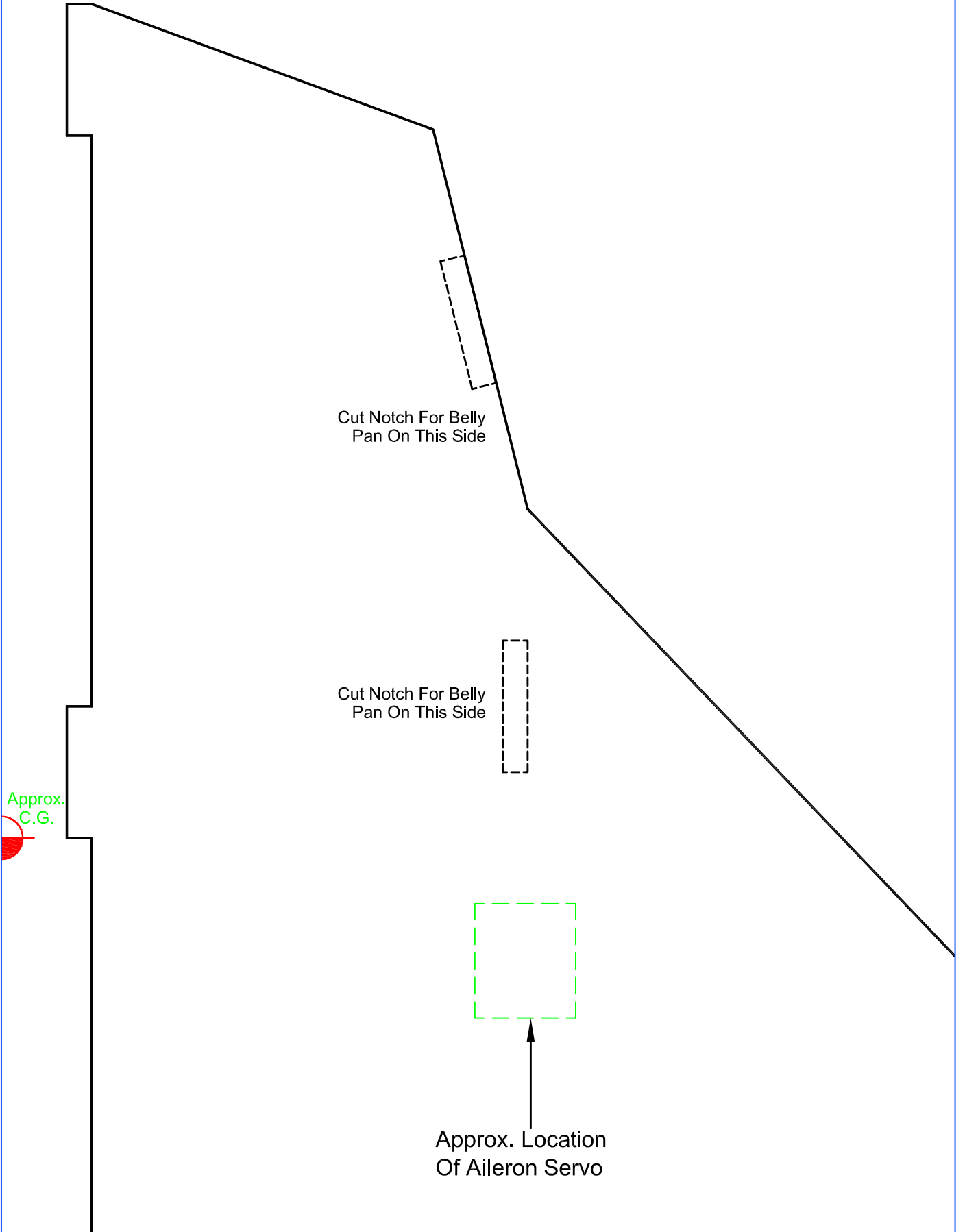

Cut Notch For Belly Pan On This Side

Cut Notch For Belly Pan On This Side

Approx. C.G.

Approx. Location Of Aileron Servo

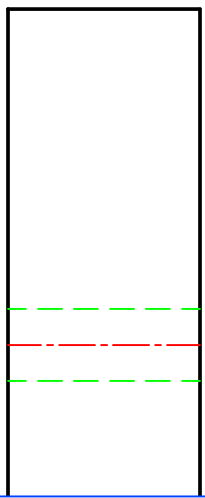
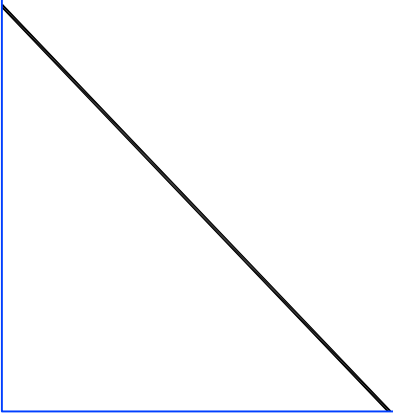
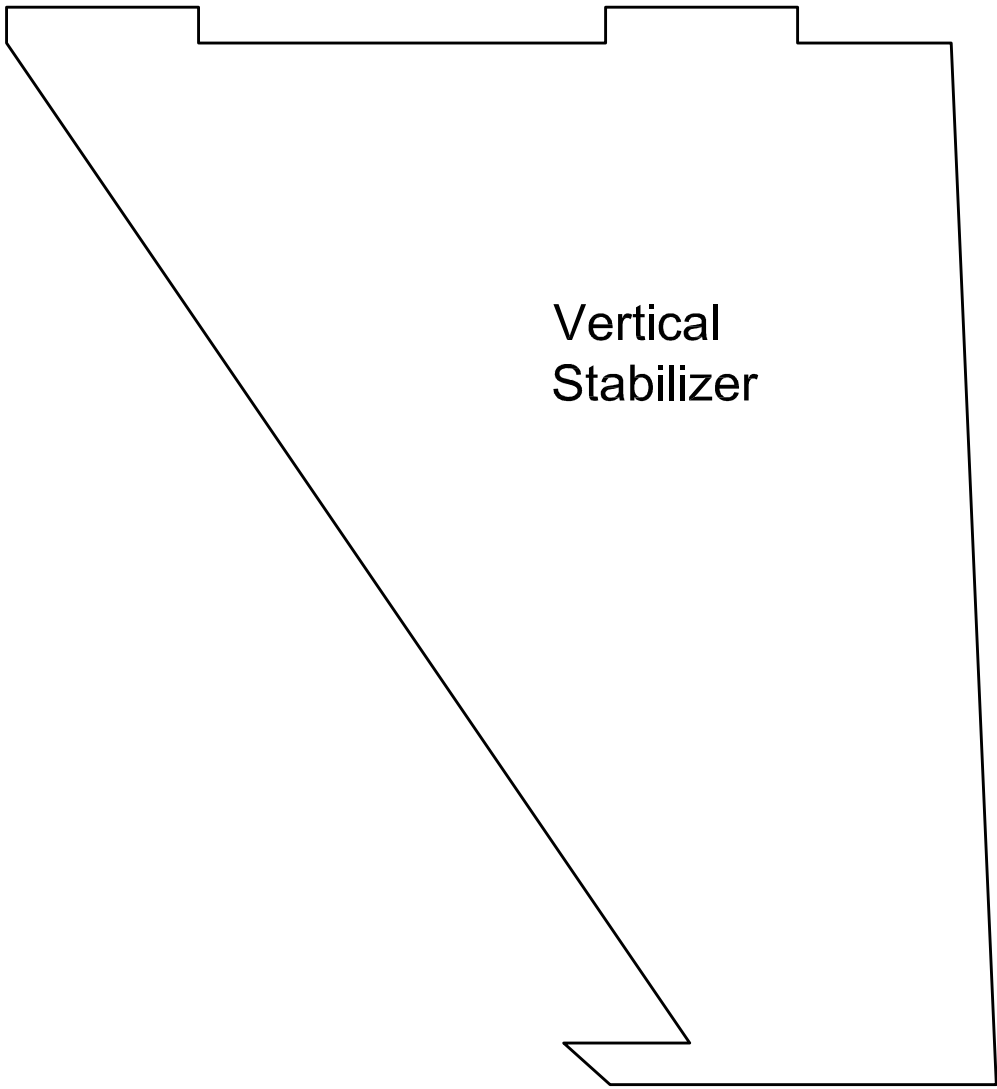

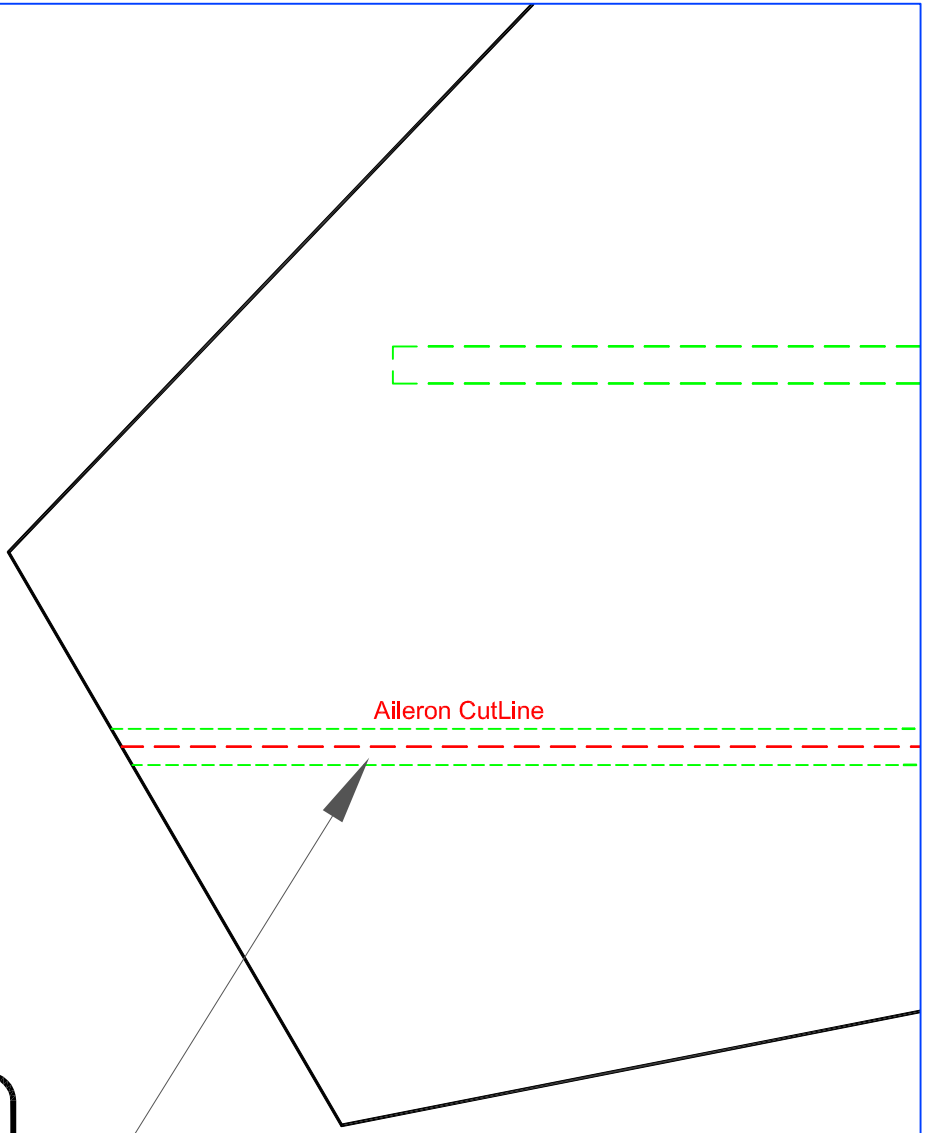

Example of SINGLE 45°
Bevel Cut on Ailerons.

(Side View)

(Isometric View)

The inset box contains two views of a beveled cut on an aileron. The top view is labeled "(Side View)" and shows a rectangular block with a V-shaped notch cut into its top surface. The bottom view is labeled "(Isometric View)" and shows a 3D perspective of the same block with the beveled cut, with green lines highlighting the beveled edges.

Carbon Spar Location

(Carbon spar is optional for Foamboard, required for Depron or Blue Core Foams.)



Cut Notch For Belly Pan On This Side



(PROP SLOT MAY NEED TO BE ADJUSTED)



Cut Notch For Tail Fin On Opposite Side



Cut Notch For Belly Pan On This Side



Approx. Location Of Elevator Servo

Cut Notch For Tail Fin On Opposite Side



Cut Notch For Belly Pan On This Side



Cut Notch For Belly
Pan On This Side

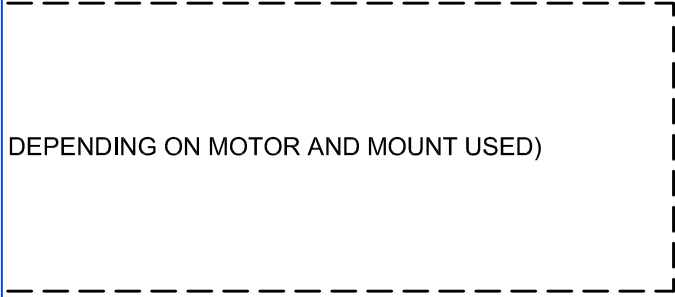

DEPENDING ON MOTOR AND MOUNT USED)

Cut Notch For Tail Fin
On Opposite Side

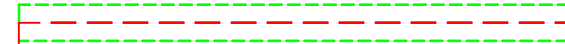

Cut Notch For Belly
Pan On This Side

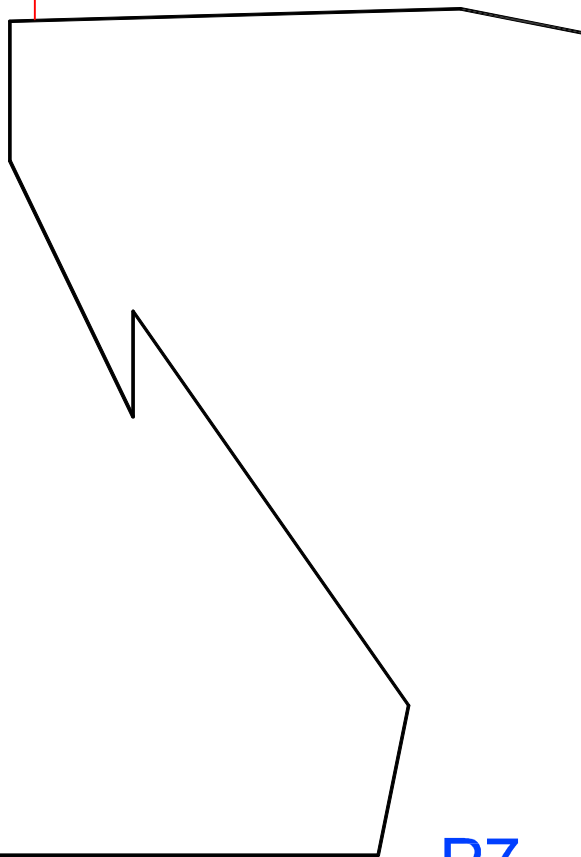

Cut Notch For Tail Fin
On Opposite Side



Cut Notch For Belly
Pan On This Side



BATTERY
TRAY

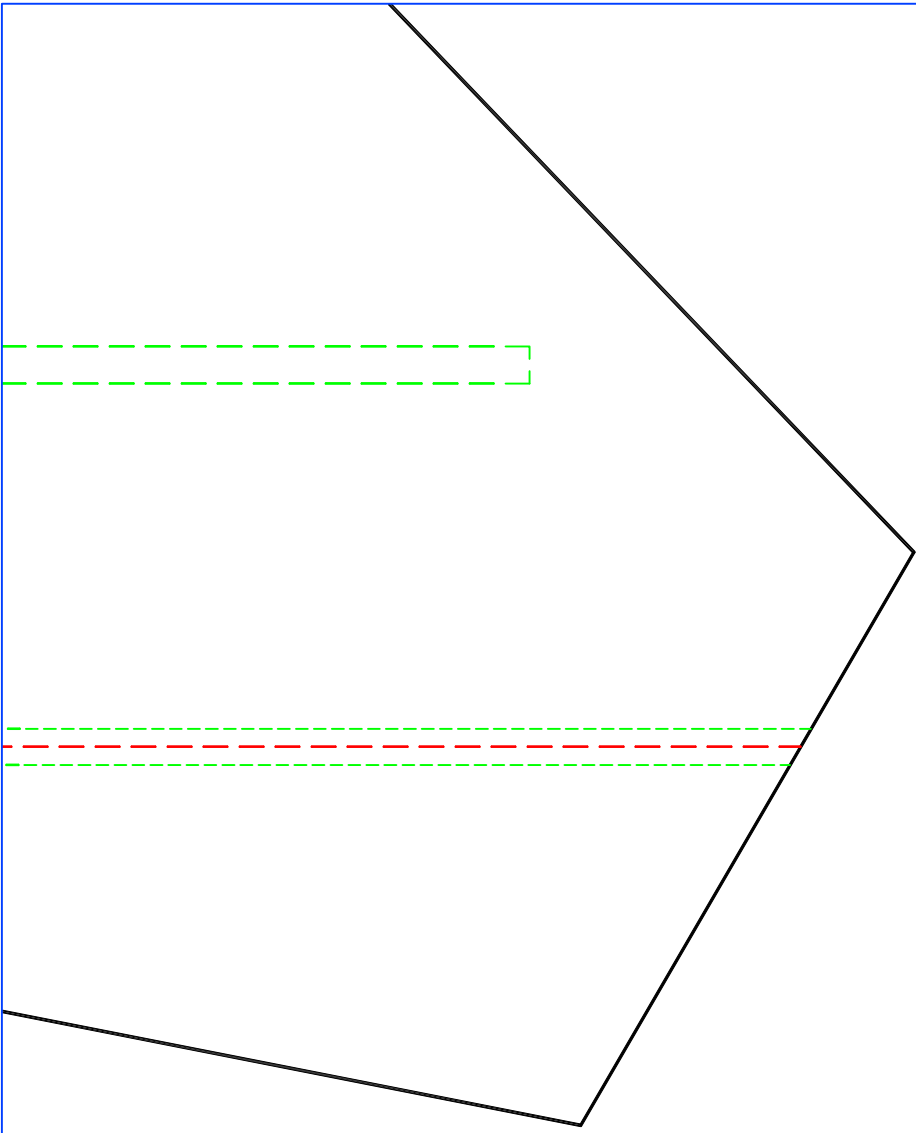

P9

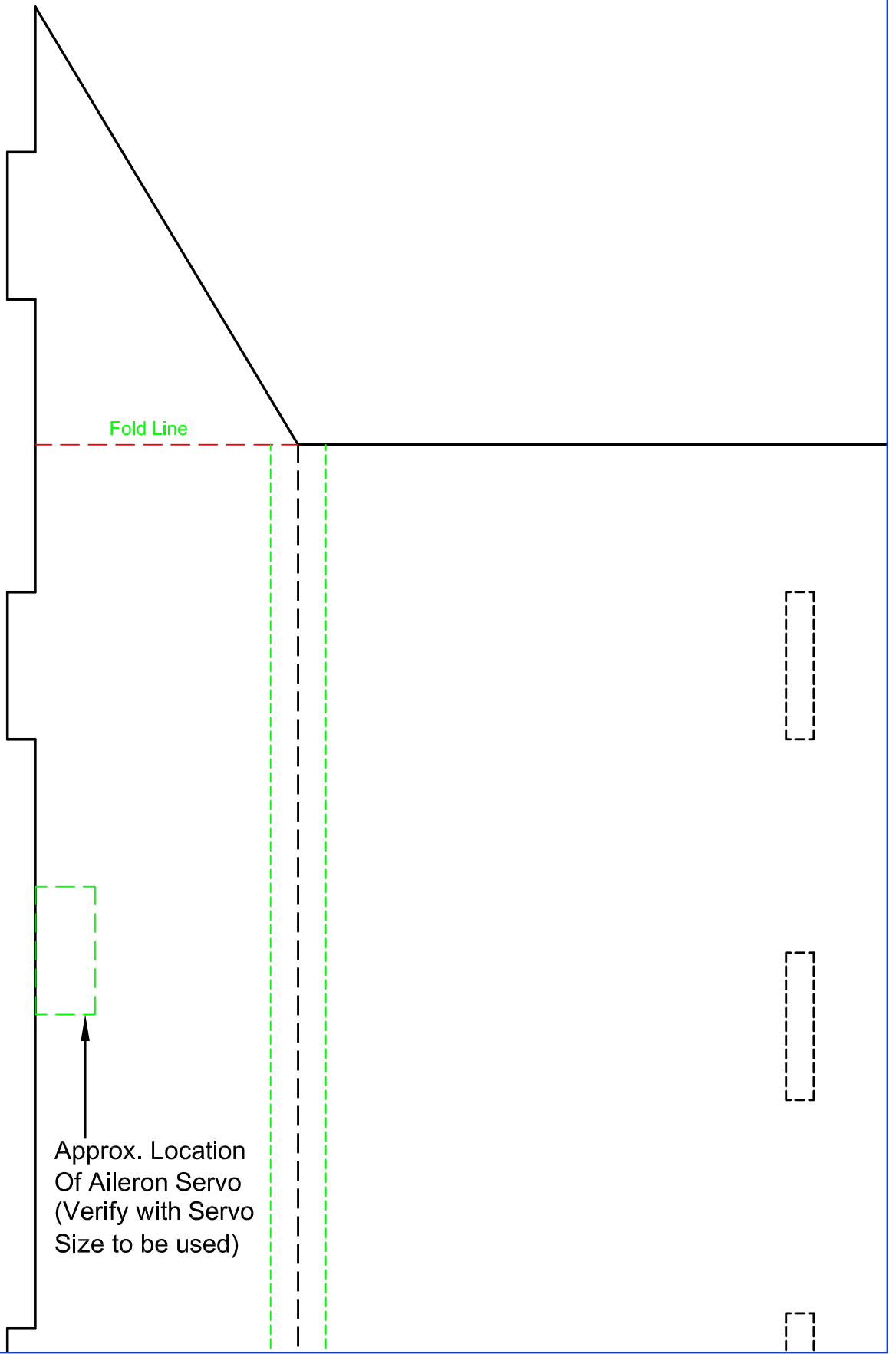

P10

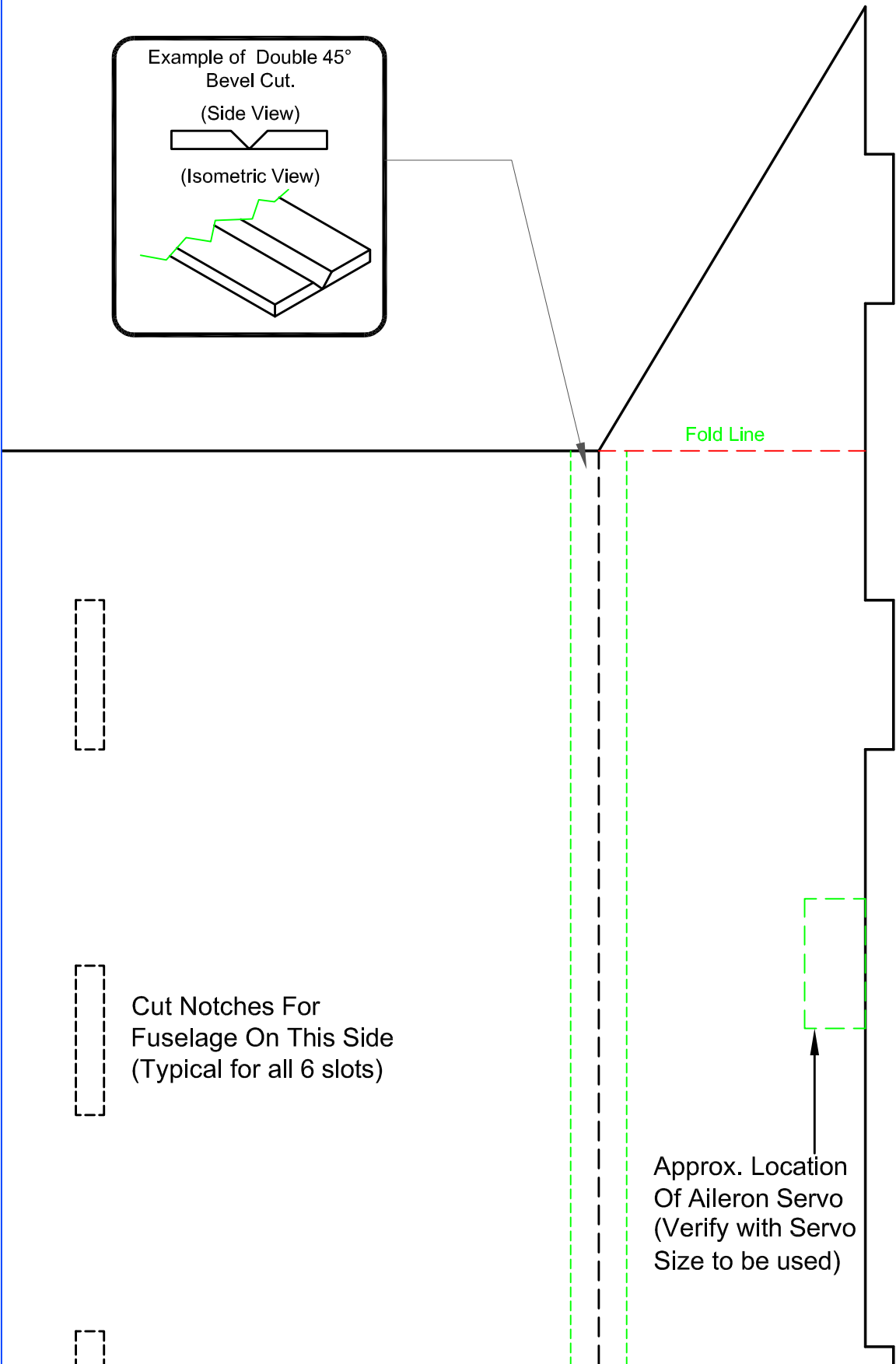
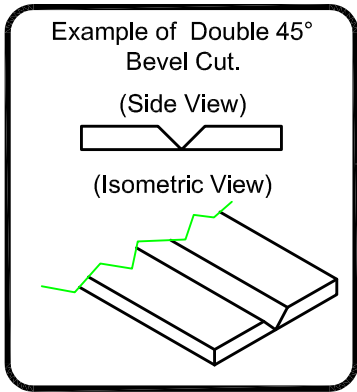

Fold Line

Cut Notches For Fuselage On This Side (Typical for all 6 slots)

Approx. Location Of Aileron Servo (Verify with Servo Size to be used)

P11

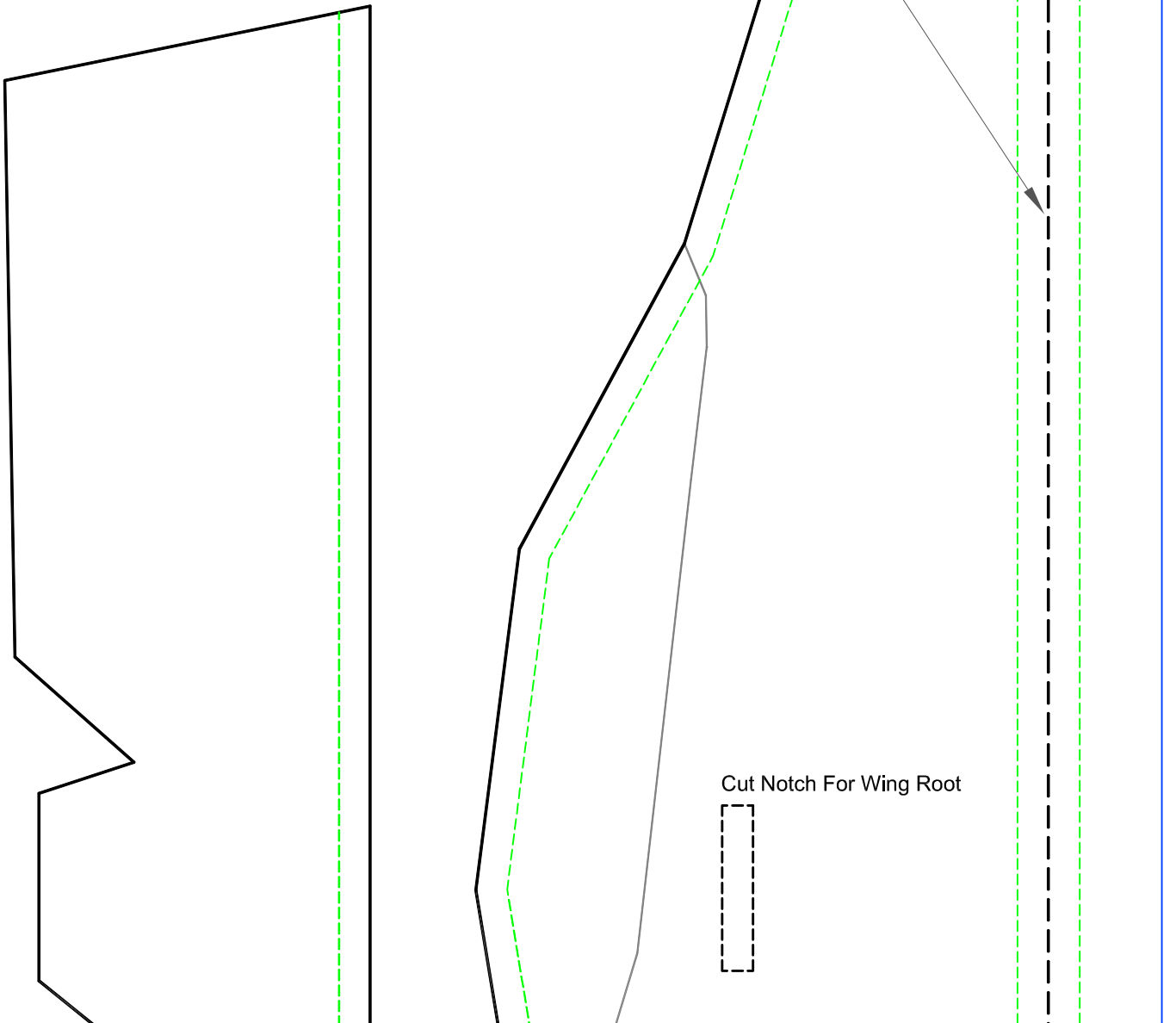
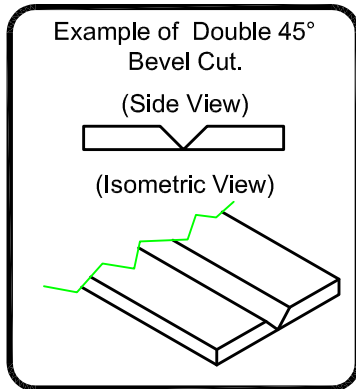

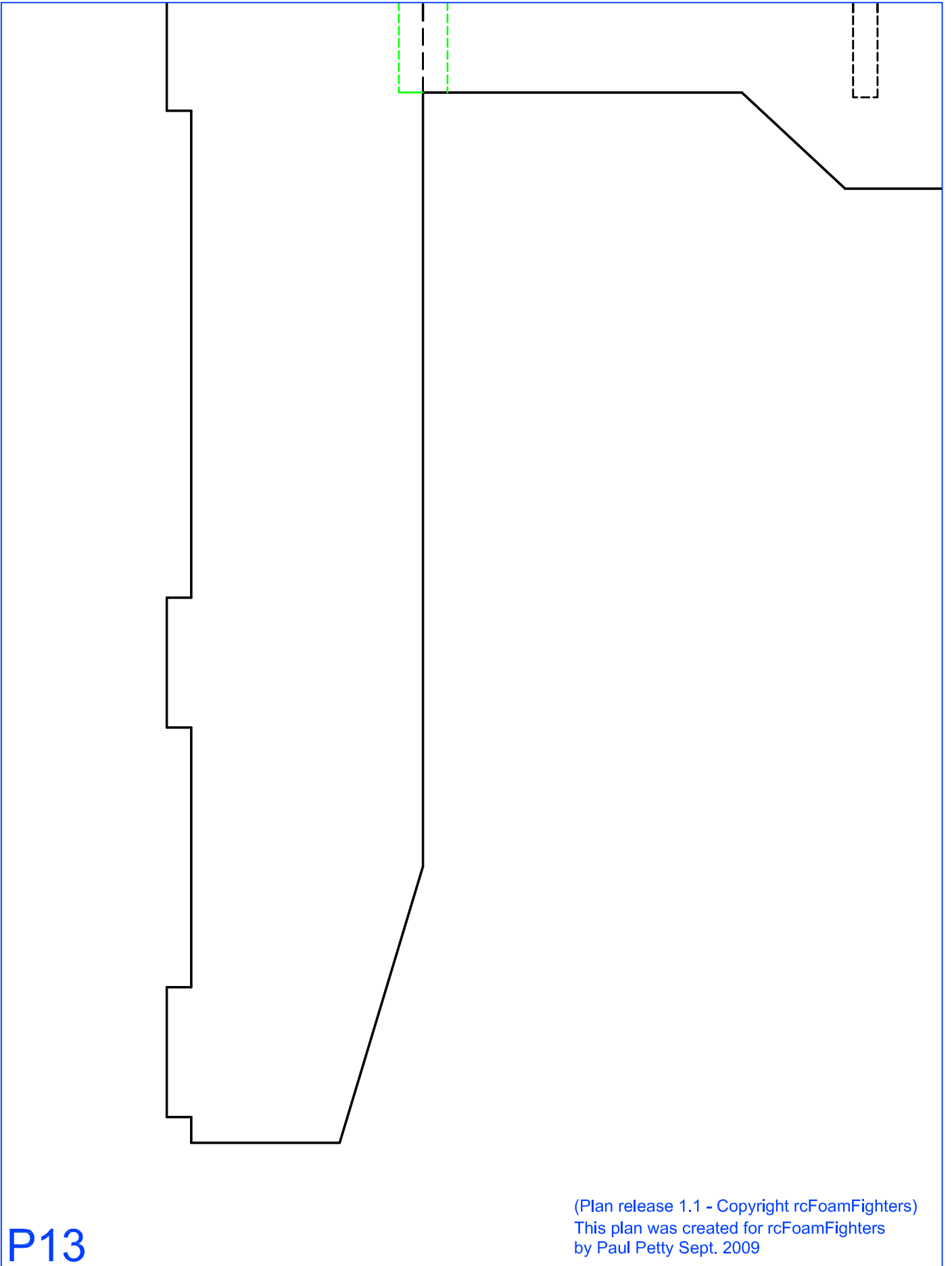

P13

(Plan release 1.1 - Copyright rcFoamFighters)
This plan was created for rcFoamFighters
by Paul Petty Sept. 2009

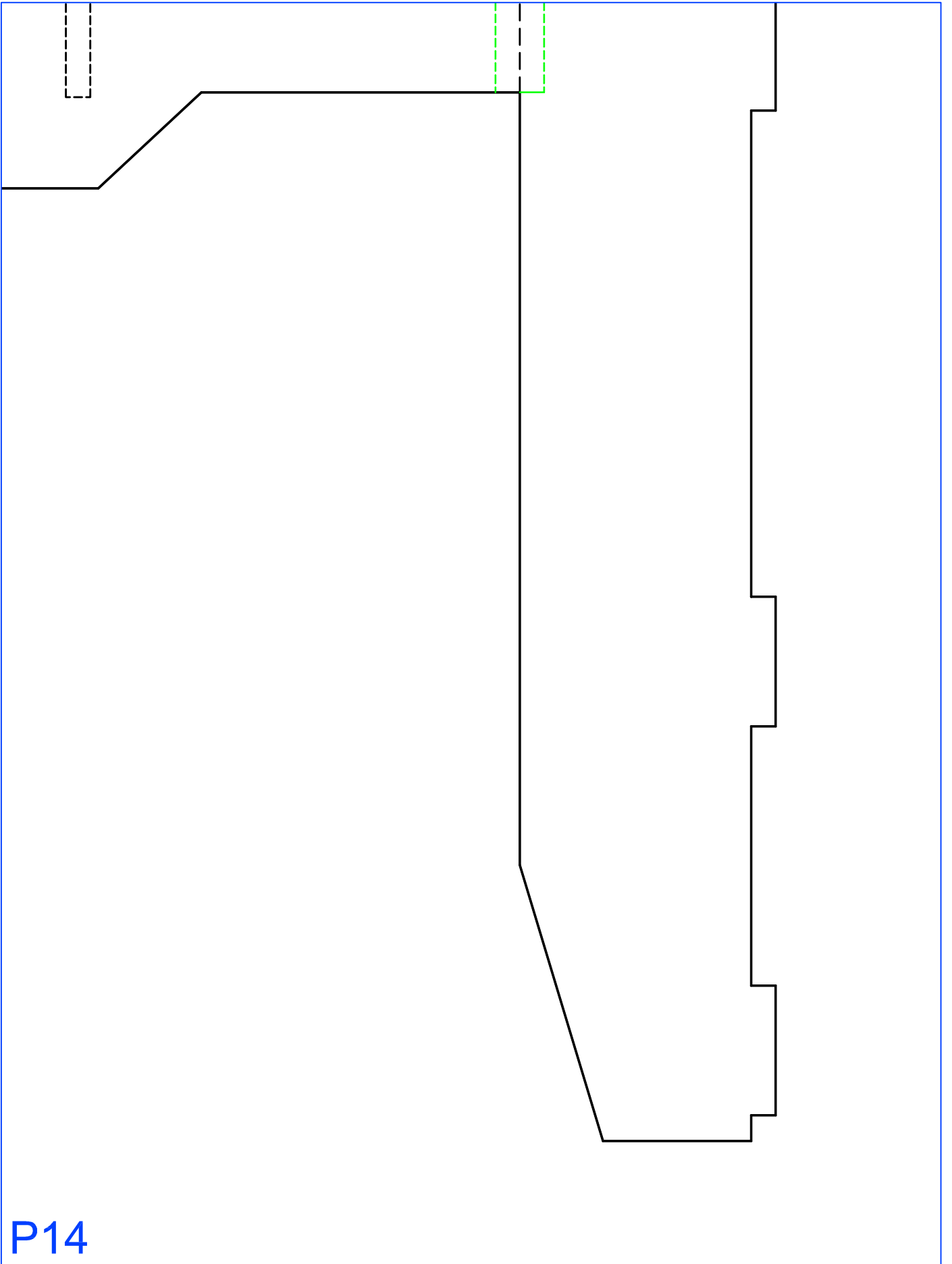

P14

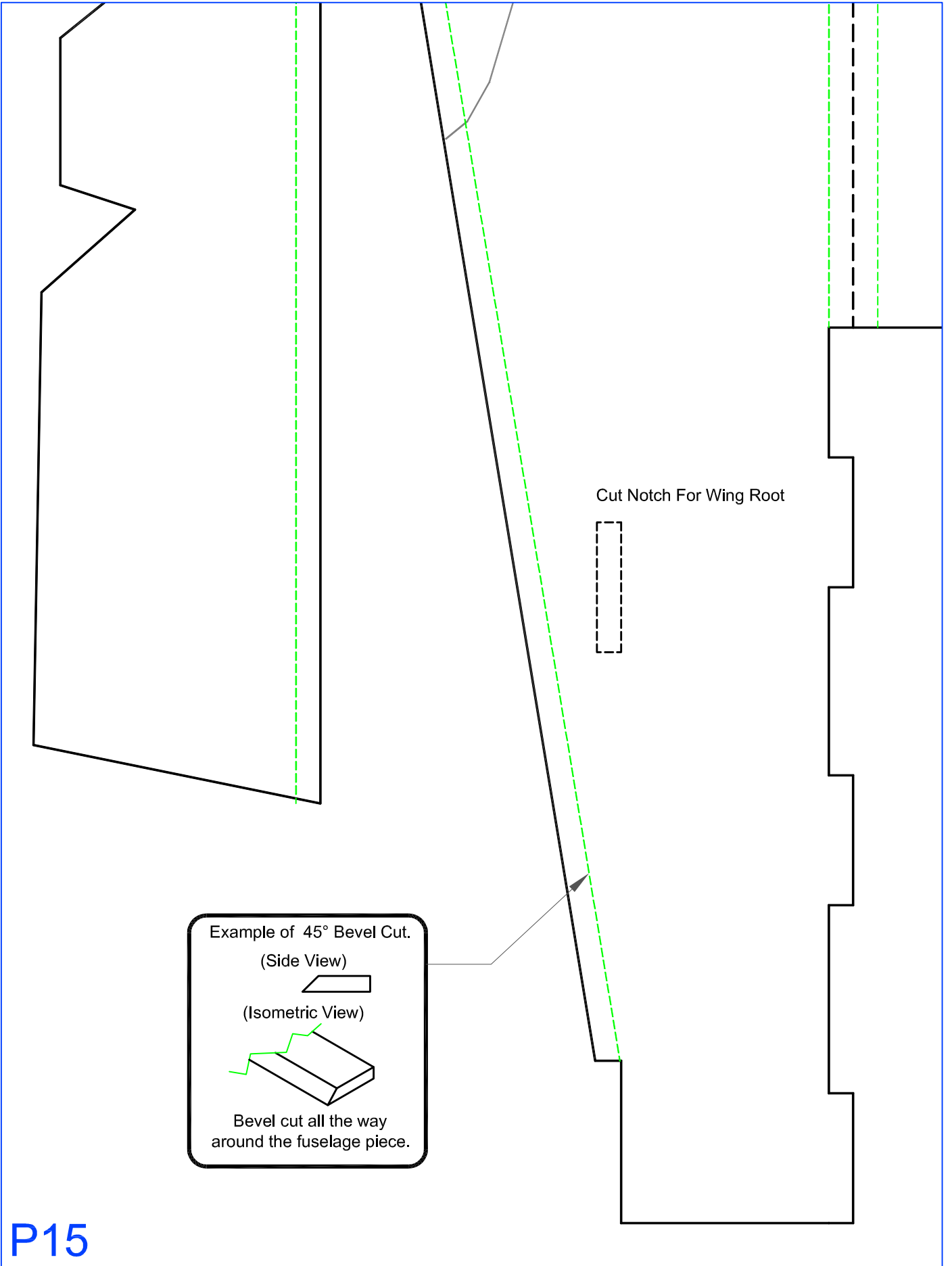

Cut Notch For Wing Root

Example of 45° Bevel Cut.
(Side View)
(Isometric View)
Bevel cut all the way around the fuselage piece.

